



XMP2-32 series

Integral industrial controller

Operating manual

Catalog

1. XMP2-32 introduction	4
1-1 Performance and characteristic	4
1-2 Specs	4
1-2-1 General specs	4
1-2-2 HMI specs	5
1-2-3 PLC specs	5
1-2-4 Product type	6
1-2-5 Name rule	6
1-3 Part name	7
1-3-1 LED display	8
1-3-2 Download port	8
1-3-3 Com port	9
1-3-4 Port A and B	9
1-4 Outline dimension	9
2. In-out specs and exterior layout	10
2-1 Input specs and layout	10
2-2 Output specs and layout	11
3. PLC function and using	13
3-1 PLC instruction	13
3-2 Soft component range	14
3-3 Build a project	16
3-4 Communication function	18
3-4-1 Com port	18
3-4-2 Communication parameters	18
3-4-3 Communication mode	20
4. HMI function and using	21
4-1 HMI function	21
4-2 Build a project	23
5. The extension ability	25
5-1 Summarization	25
5-2. Extend MA model	26

1. XMP2-32 introduction

1-1 Performance and characteristic

XMP2-32R-E (relay output type) and XMP2-32T-E (transistor output type) are integrated with HMI (MP series) and PLC (XC2 series) perfectly. They can totally instead of HMI and PLC in control system with the premiss of meeting the control requests. Small profile can save space and improve the maintenance convenience.

- ◆ XMP2-32 = MP760-T + XC2-32
- ◆ Integrated with logical control, analog quantity in-out, HMI (human machine interface)
On-off input: 16 points
On-off output: 16 points
- ◆ HMI screen: editing simply and directly, rich function, touchable display area
- ◆ LCD display: 480×234 pixel, 7 inch screen, LCD life can reach 0.5 million hours
- ◆ 26 function keys, function setting freely, sensitive and precise key-press
- ◆ Support high speed count, high speed pulse, external interrupt
- ◆ Mix function designed download port: the same cable for downloading HMI and PLC program
- ◆ Waterproof level is IP20
- ◆ Close construction, save the space of electric control cabinet
- ◆ Simple, modern and decent appearance

1-2 Specs

1-2-1 General specs

Input voltage	AC220V or DC24V
Power	Less than 10W (TYP2.0W)
Instant power off allowance	Less than 20ms
Voltage endurance	AC1000V-10mA 1 minute between signal and ground
Insulated impedance	DC500V about 10MΩ (between signal and ground)
Operating temperature	0~50℃
Conservation temperature	-10~60℃
Environment temperature	20~85% (no dew)
Oscillation endurance	10~25Hz (X,Y, Z direction for 30 minutes 2G)

Anti-jamming	Voltage noise: 1000Vp-p
Air condition	No causticity gas
Protect construction	According to IP20

1-2-2 HMI specs

Characteristic	Type	TFT 256-colour LCD
	Screen dimension	7 inch
	Use life	Over 50000 hours, 25°C, 24 hours operating
	Display area	480*234
	Contrast	Unable to change
	Character setting	Chinese, English, Japanese, Korean, etc.
	Character size	Free size and font
	Touch mode	Digital mode touch
Register	Picture	8MB Flash ROM
	Data	4KB SRAM
Interface	Communicate port	RS-232/RS-485
	Download port	RS-232

1-2-3 PLC specs

Item	Specs	
	XMP2-32	
Program executing format	Loop scan format, time scan format	
Program format	Instruction, C language and ladder chart	
Processing speed	0.5us	
Power cut retaining	Use Flash ROM and Li battery	
User program's capacity	128KB	
I/O points	Input 16 points, output 16 points	
Interior coil's points (M)	8767	
Timer (T)	Points	640
	Specs	100mS timer: Set time 0.1~3276.7 seconds 10mS timer: Set time 0.01~327.67 seconds 1mS timer: Set time 0.001~32.767 seconds
Counter (C)	Points	640
	Specs	16 bits counter: set value K0~32767 32 bits counter: set value -2147483648~2147483647
Data Register (D)	2612 words	
Flash ROM Register (FD)	512 words	

High speed processing function	High speed count、 pulse output、 external interrupt
Setting of time scan space	0~99mS
Password protection	6 bits ASCII
Self diagnose function	Power on self-diagnose、 Monitor timer、 grammar check

1-2-4 Product type

XMP-32 series	
Relay output	Transistor output
XMP2-32R-E	XMP2-32T-E
XMP2-32R-C	XMP3-32T-C

NOTE:

-E means the power supply is AC220V

-C means the power supply is DC24V

1-2-5 Name rule

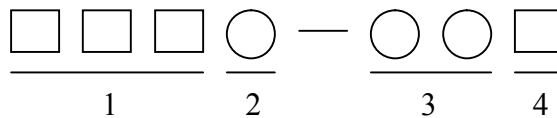

1: series name

2: PLC type

3: I/O points

4: output type

XMP

2: XC2 series

32: input 16/output 16 points

R: relay output

T: transistor output

1-3 Part name

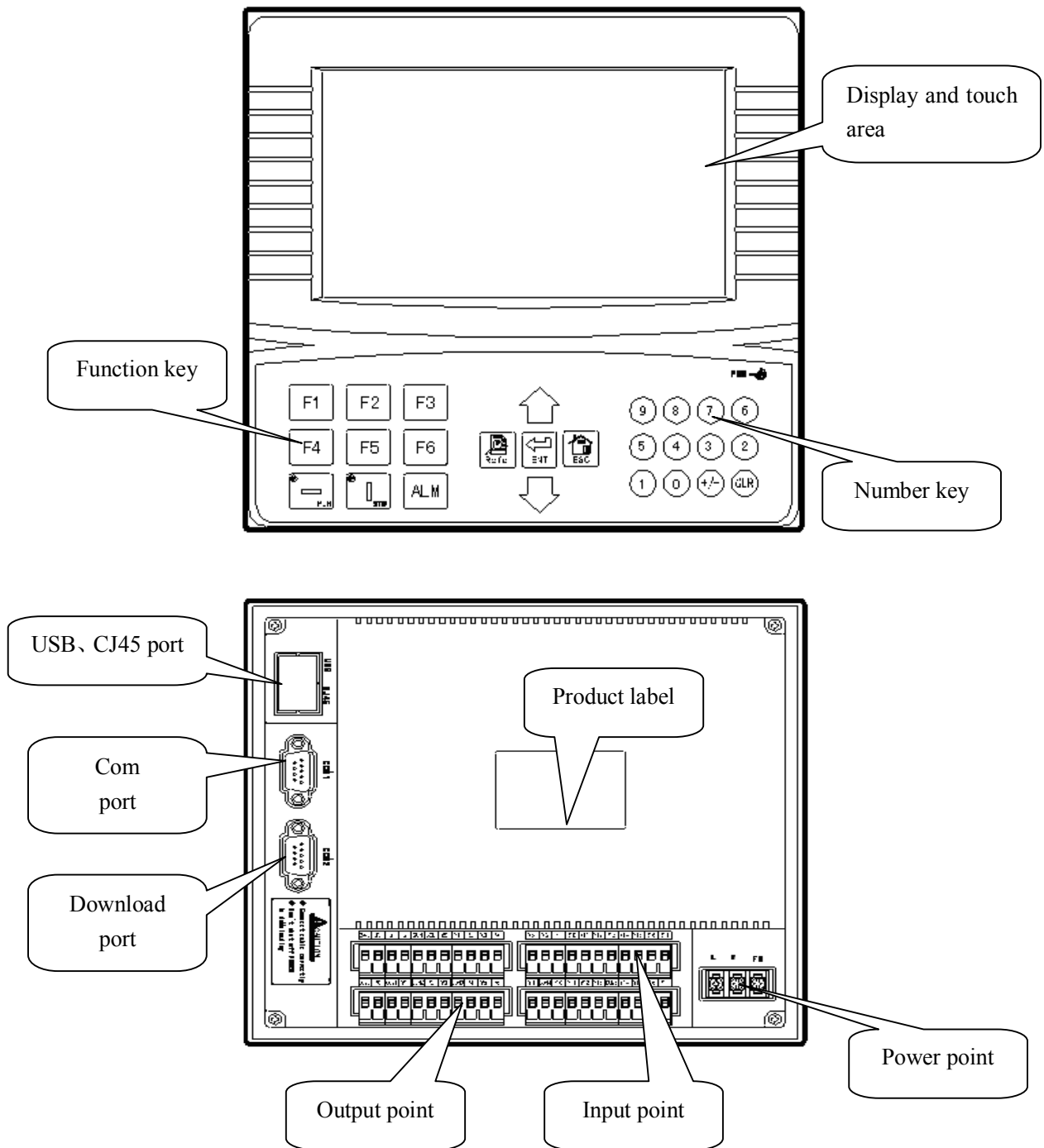

1-3-1 LED display

PWR: Power supply

RUN: program running

STOP: program stop

1-3-2 Download port

- The port is RS-232 standard and double function designed, is able to download PLC program and HMI program.

Pin2	RXD
Pin3	TXD
Pin5	GND
Pin7	RTS

- Used as RS-485 com port: for HMI connecting with slave device

Pin1	A
Pin9	B
Pin6	PRT (when HMI connecting with slave device, short pin 5&6)
Pin8	DOWNLOAD (short pin 5&8 to forced-download HMI program)

Cable connection figure:

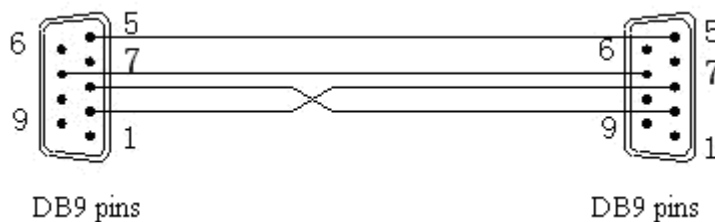

Attention:

- (1) Do not cut the power when downloading, or you have to download again
- (2) The cable of downloading HMI program is the same as the downloading PLC program
- (3) Do not download when XCPPro and Touchwin software are both running
- (4) RS-232 download port is only used to download, do not use it in other way

1-3-3 Com port

The port is RS-232 standard, is used to connect PC and HMI.

Pin2	RXD
Pin3	TXD
Pin5	GND

1-3-4 Port A and B

The port is RS-485 standard, is used to connect meter, inverter, extension model, etc.

Attention:

A, B port and RS-232 com port are the same port, can not be used at the same time.

1-4 Outline dimension

Outline dimension (mm):

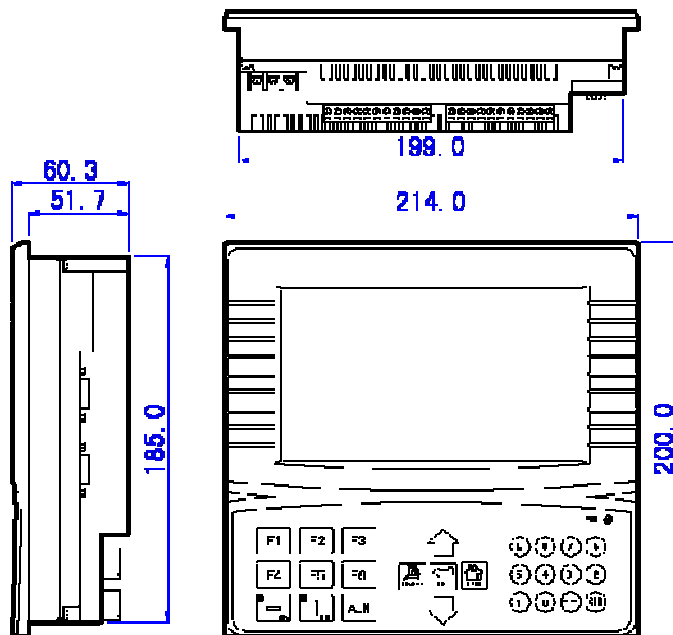

Installate dimension (mm):

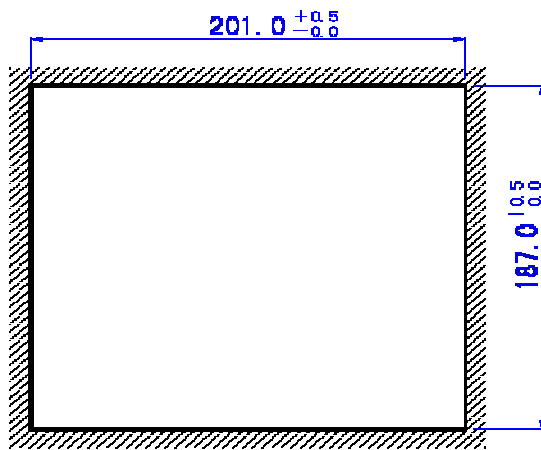

2. In-out specs and exterior layout

2-1 Input specs and layout

Input specs:

Input signal voltage	DC24V \pm 10%
Input signal current	7mA/DC24V
Input ON current	Above 4.5mA
Input OFF current	Below 1.5mA
Input response time	About 10ms
Input signal format	Point input or NPN collector open transistor
Circuit insulation	Photo-electricity coupling insulation
Input action display	LED is ON when input ON

Input connection figure:

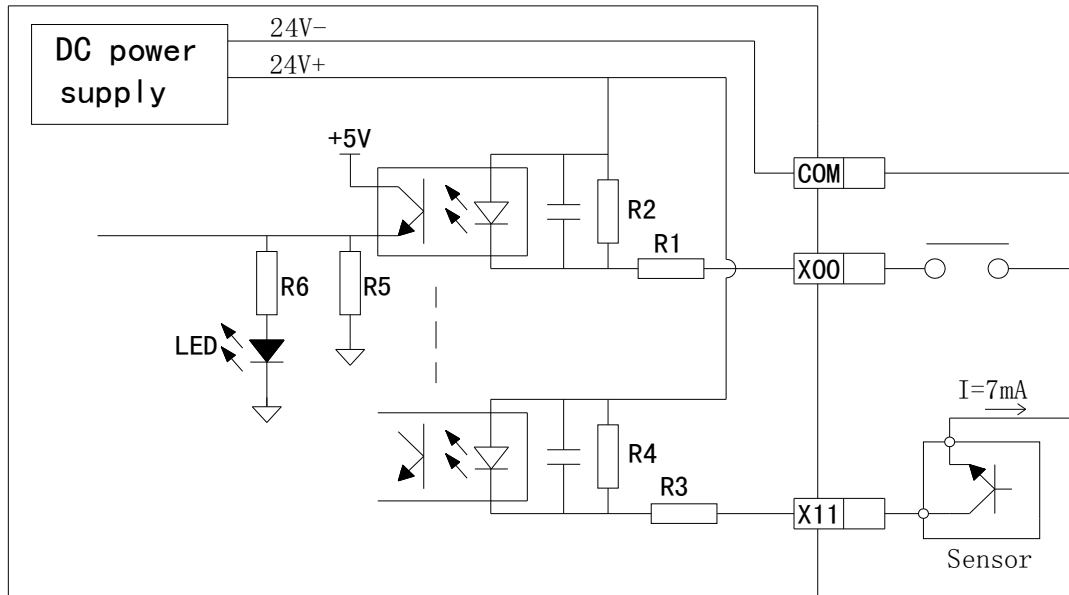

Input point arrangement:

24V	0V	A	B	COM	COM	X0	X1	X2	X3	X4	X5	X6	X7	X10	X11	X12	X13	X14	X15	X16	X17
-----	----	---	---	-----	-----	----	----	----	----	----	----	----	----	-----	-----	-----	-----	-----	-----	-----	-----

2-2 Output specs and layout

Relay output:

Interior power		Below AC250V、DC30V
Circuit insulation		Machine insulation
Action indication		LED light
Max load	Resistor load	3A
	Induction load	80VA
	Light load	100W
Open creepage current		No
Minimum load		DC5V 2mA
Response time	OFF→ON	10ms
	ON→OFF	10ms

Transistor output:

Interior power		Below DC5~30V
Circuit insulation		Optical coupling insulation
Action indication		LED light
Max load	Resistor load	0.8A
	Induction load	12w/DC24V
	Light load	1.5W/DC24V

Open creepage current	< 0.1 mA	
Minimum load	DC5V 2mA	
Response time	OFF→ON	0.2ms
	ON→OFF	0.2ms

Output connection figure:

◆ Relay output:

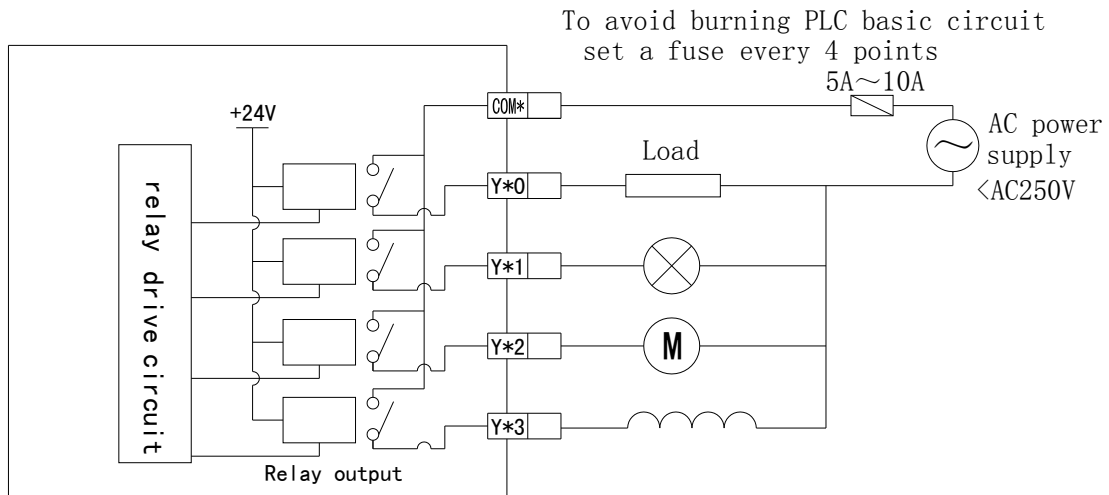

◆ Transistor output connection

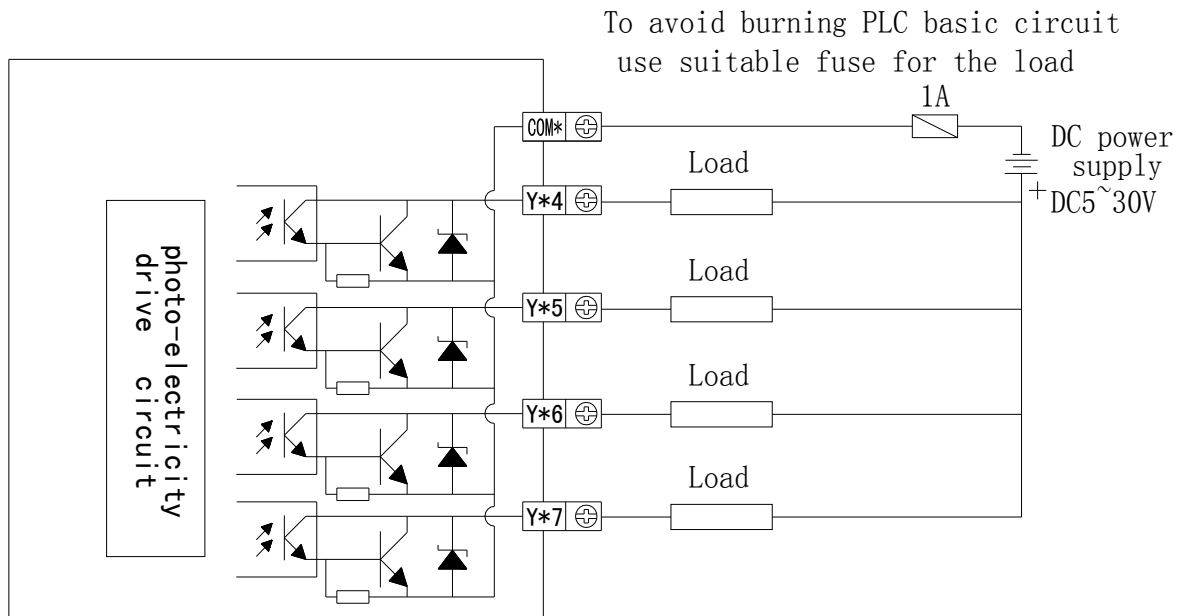

Output point arrangement:

COM0	Y0	COM1	Y1	COM2	Y2	Y3	COM3	Y4	Y5	Y6	Y7	COM4	Y10	Y11	Y12	Y13	COM5	Y14	Y15	Y16	Y17
------	----	------	----	------	----	----	------	----	----	----	----	------	-----	-----	-----	-----	------	-----	-----	-----	-----

3. PLC function and using

3-1 PLC instruction

XMP2-32 series product used XC2 series PLC, the PLC instructions are the same as XC2-32. It contains SFC instructions, applied instructions and special function instructions. Please refer to XC Series PLC Manual: paragraph 4, 5,6.

Here listed in-out point definition and distribution of special function instructions for your information.

1. high speed count

(1) Increment mode: 5 channels

Channel	Input	Counter	Highest frequency
CHL1	X0	C600	80KHZ
CHL2	X1	C602	80KHZ
CHL3	X3	C604	10KHZ
CHL4	X6	C606	10KHZ
CHL5	X7	C608	10KHZ

(2) Pulse + direction mode: 2 channels

Channel	Input		Counter	Highest frequency
	Pulse	Direction		
CHL1	X0	X1	C620	80KHZ
CHL2	X3	X4	C622	10KHZ

(3) AB phase mode: 2 channel

Channel	Input		Counter	Highest frequency
	Phase A	Phase B		
CHL1	X0	X1	C630	80KHZ
CHL2	X3	X4	C632	5KHZ

2. High speed pulse output

- a) T type: Y0, Y1 available, the highest frequency is 200KHz
- b) R type: unavailable

3. Interrupt function

Channel	Input	Pointer tag		Disable interruption instruction
		Rising interruption	Falling interruption	
CHL1	X2	I0000	I0001	M8050
CHL2	X5	I0100	I0101	M8051
CHL3	X10	I0200	I0201	M8052

4. Frequency measurement

The point is X1, X6, X7.

5. Pulse width modulation (PWM)

The point is Y0, Y1.

- ◆ T type: Y0, Y1 available
- ◆ R type: unavailable

6. Precise timer

32 bit precise timer, the timer range is T600 to T618, match with 10 interruption tag.

3-2 Soft component range

Soft component	Name	Range	Point
X	Input point	X000~X017(octal)	16
Y	Output point	Y000~Y017(octal)	16
M	Auxiliary relay	M0~ M2999 【M3000~M7999 】	8000
		M8000~M8767	768
S	Process	S0~ S511 【S512~M1023 】	1024
T	Timer	T0~T99: 100ms not accumulation	640
		T100~T199: 100ms accumulation	
		T200~T299: 10ms not accumulation	
		T300~T399: 10ms accumulation	
		T400~T499: 1ms not accumulation	
		T500~T599: 1ms accumulation	
		T600~T618: 1ms with interruption precise time	
		T620~T639: vacant	
C	Counter	C0~C299: 16 bits forth counter	640

		C300~C599: 32 bits forth/back counter	
		【C600~C619】: one phase high speed counter	
		【C620~C629】: Pulse + direction high speed counter	
		【C630~C639】: AB phase high speed counter	
D	Data register	D0~D999 【D4000~D4999】	2000
		For special using D8000~D8511 D8630~D8729	612
FD	Flash ROM register	FD0~FD127	128
		For special using FD8000~FD8383	384

NOTE:

- ※1. The memorizer area in 【 】 is the defaulted power failure retentive area, the power failure retentive area of soft components D, M, S, T, C can be set via FD register. For the details, please see the following table.
- ※2. Flash ROM register needn't set power failure retentive area, its data won't lose when power is cut (No battery).
- ※3. The serial number of input coil and output relay are octal data, other memorizers' number are all decimal data.
- ※4. There is no I/O point connected with exterior device can be used as interior relay.

Soft component power failure area setting:

Soft component	Area	Function	Default value	Power failure memory area
D	FD8202	First address of the power failure memory area of D	4000	D4000~D4999
M	FD8203	First address of the power failure memory area of M	3000	M3000~M7999
T	FD8204	First address of the power failure memory area of T	640	-
C	FD8205	First address of the power failure memory area of C	320	C320~C639
S	FD8206	First address of the power failure memory area of S	512	S512~S1023

NOTE:

Users can set the power failure memory area by themselves, but the area can not over the soft component area.

3-3 Build a project

XMP2-32 series products are integrated with XC series PLC and HMI. When editing PLC program, please use XCP Pro software which is the same as XC series PLC.

1. select the product type

Open XCPPro, click “file---change PLC model”:

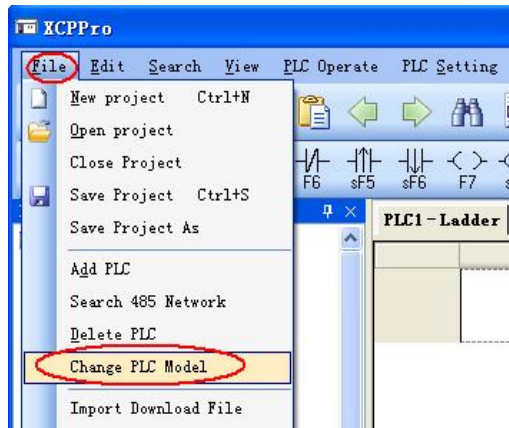

Select “XMP2-32”:

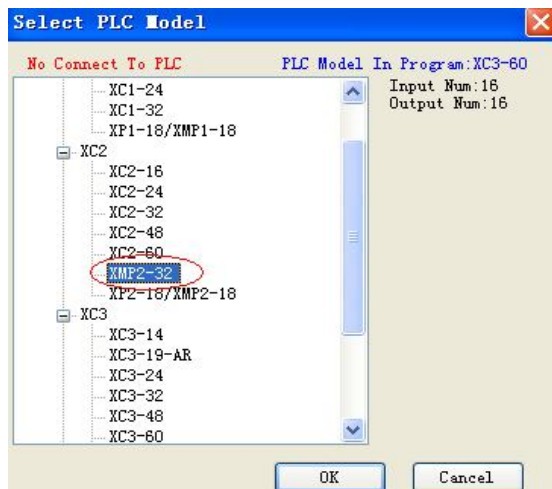

2. edit the PLC program

After selecting the type, user can edit the program in the software. The editing specs and operating details please refer to XC Series PLC Edit Software XCPPro Manual.

The interface of software is as below:

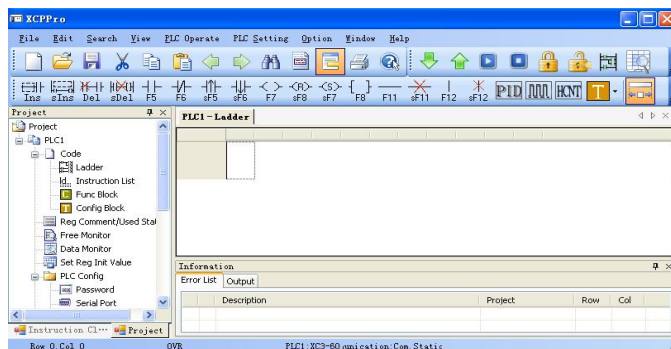

3. download program

After editing and saving the program, users need to download them to XMP. Before downloading, ensure the XMP has connected with computer successfully. (Please refer to chapter 1-3-2 for cable connection).

Click  to open software serial port configuration

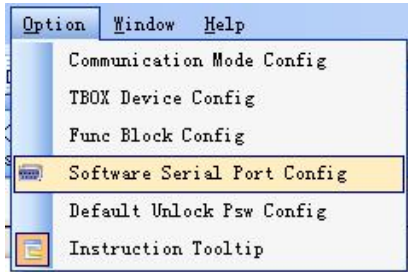

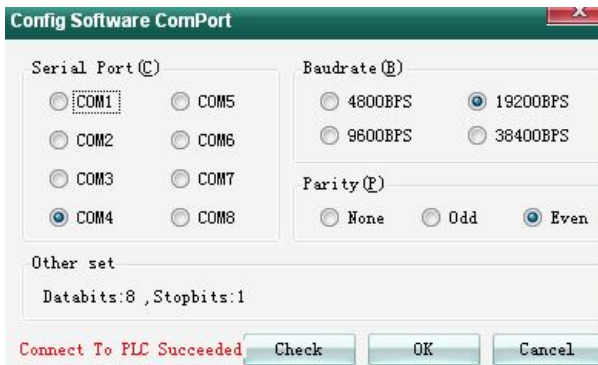

Choose the correct serial port, baud rate and parity or click “check” to choose these parameters automatically.

When below window shows “connect to PLC succeeded”, it means the connecting is successful. Click OK to continue.

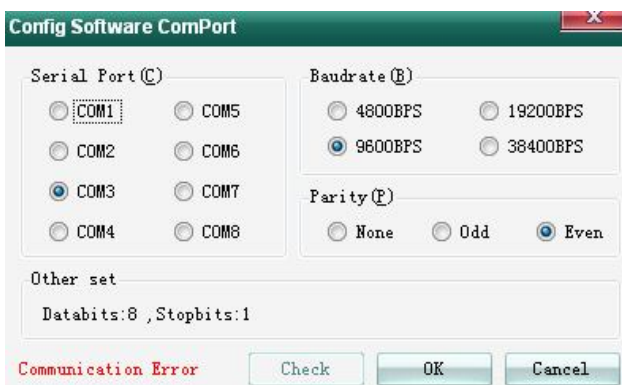

If the connecting is not successful, the window will show “communication error”. Please check the serial port and the cable.



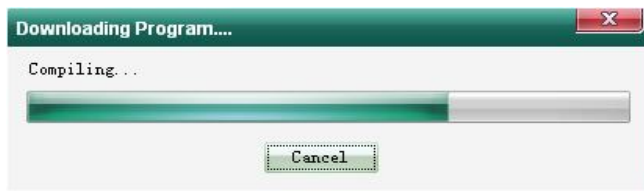

After connecting successfully, click  to download the PLC program. If the PLC is running, it will pop up the stop running window, click OK to continue downloading.



After downloading, click  to run the PLC program.

2 Upload the program

If you want to check the PLC program in XMP2-32, click  to upload the program to the PC. Then click  to save the program.

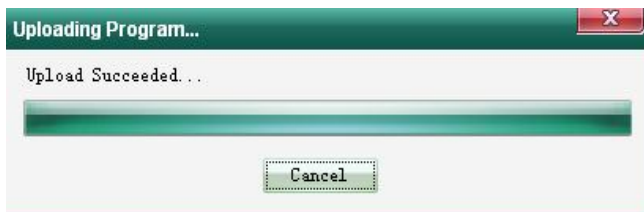

3-4 Communication function

XMP2-32 series support Modbus and free format communication protocol. The instructions please refer to XC Series PLC Operating Manual paragraph 6-4-1 and 6-4-2.

3-4-1 Com port

XMP2-32 series product have program port (DB9 pins port), RS-232 com port (DB9 pins port) and RS-485 com port (A and B point). Program port can only be used to download PLC program and HMI pictures. However, RS-232 and RS-485 com port can be used to communicate with other devices. The communication parameters (baud rate, data bit, etc) can be set via software. RS-485 com port point A means “+” signal, point B means “-” signal.

Attention:

RS-485 and RS-232 com port are the same, do not use them at the same time.

3-4-2 Communication parameters

Communication parameters of RS-232 and RS-485 com port can be set via FLASH register in XMP.

The defaulted parameters:

Station 1, baud rate 19200bps, 8 data bits, 1 stop bit, even check

Station No.	Modbus station No. : 1~254, 255(FF) is for free format communication
Baud rate	300bps~115.2Kbps
Data bit	8 or 7 bits
Stop bit	2 or 1 bits
Check	Even, odd, no check

Communication parameters setting are as below table:

Attention:

After changing the parameters in Flash register, it is need to reboot the XMP to make the setting become effective.

	Number	Function	Description
com port	FD8220	Communication mode (station number)	255 is free format, 1~254 is modbus station number
	FD8221	Communication format	Baud rate, data bit, stop bit, check
	FD8222	ASC timeout judgment time	Unit: ms, 0 means no timeout waiting
	FD8223	Reply timeout judgment time	Unit: ms, 0 means no timeout waiting
	FD8224	Start symbol	High 8 bits invalid
	FD8225	End symbol	High 8 bits invalid
	FD8226	Free format setting	8/16 bits cushion, with/without start bit, with/without stop bit

The way of setting communication parameters:

FD8221:

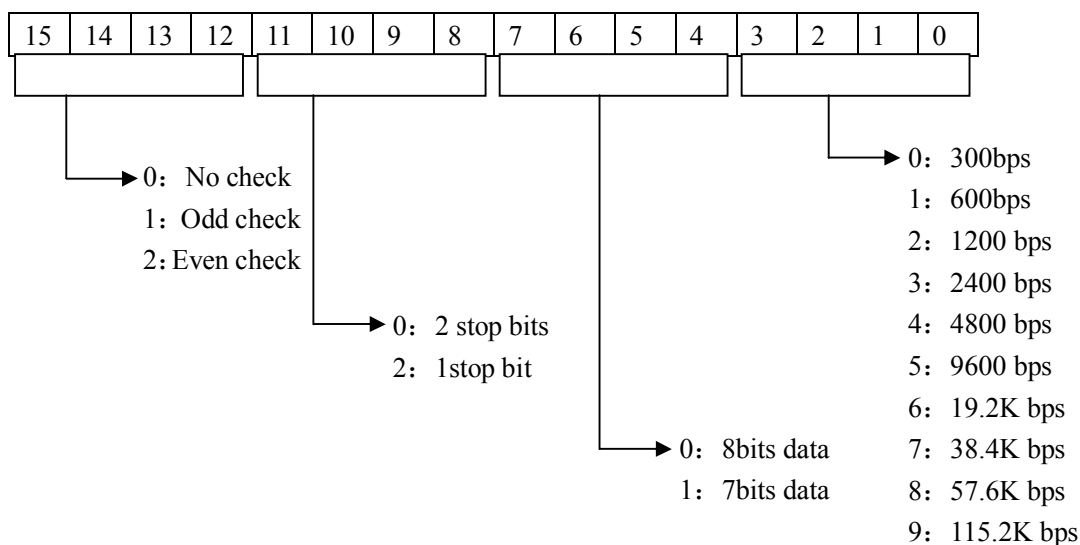

FD8226:

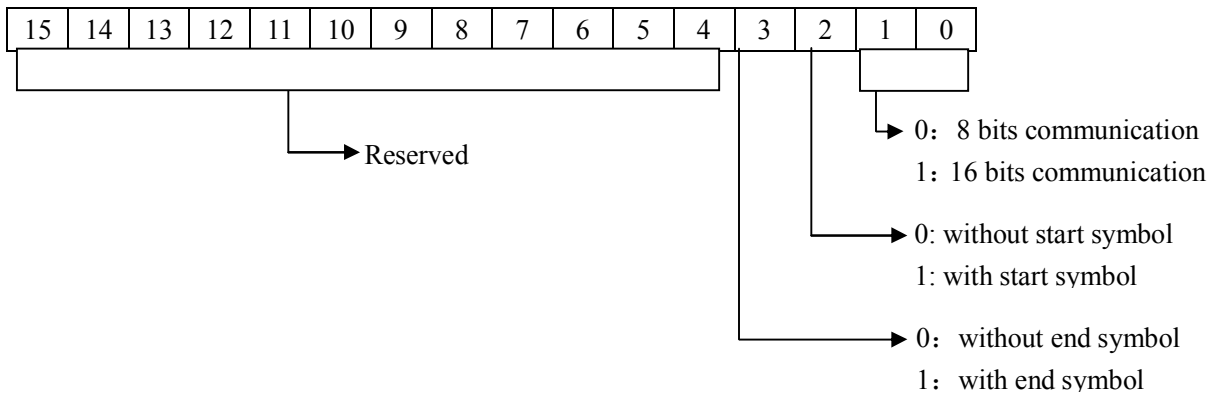

3-4-3 Communication mode

Modbus communication

XMP series product support master and slave mode of Modbus communication protocol.
 Master format: When PLC is set to be master station, PLC sends request to other slave station devices via Modbus instructions, other devices respond to the master station.
 Slave format: When PLC is set to be slave station, it can only respond to other master devices.
 The defaulted status of XMP is Modbus slave mode.

Communication address

The internal soft unit's numbers of XMP are corresponded with Modbus station address numbers, please see the following table:

Coil space: (Modbus address prefix is “ 0x ”)

Bit component address	Modbus address (decimal K)	Modbus address (hex H)
M0~M7999	0~7999	0~1F3F
X0~X1037(octal)	16384~16927	4000~421F
Y0~Y1037(octal)	18432~18975	4800~4A1F
S0~S1023	20480~21503	5000~53FF
M8000~M8511	24576~25087	6000~61FF
T0~T618	25600~26218	6400~666A
C0~C634	27648~28282	6C00~6E7A

Register space: (Modbus address prefix is “ 4x ”)

Word component address	Modbus address (decimal K)	Modbus address (hex H)
D0~D7999	0~7999	0~1F3F
TD0~TD618	12288~12906	3000~326A
CD0~CD634	14336~14970	3800~3A7A
D8000~D8511	16384~16895	4000~41FF
FD0~FD5000	18432~23432	4800~5B88
FD8000~FD8511	26624~27135	6800~69FF

Free format communication

Free format communication transfer data in the format of data block, each block can transfer 128 bytes at most. Meanwhile each block can set a start symbol and a end symbol, or not set.





When communicating in free format mode, FD8220 should be 255.









Start Symbol (1 byte)	Data Block (max bytes 128)	End Symbol (1 byte)
-----------------------	-----------------------------	---------------------

4. HMI function and using

4-1 HMI function

The HMI part of XMP2-32 series product is integrated with MP-760T touch screen. The faceplate key-presses are as below:

Key	Function
	Running the program, LED indication light
	Stop running the program, LED indication light
	Whatever the mode of the display is in, it will return to original system screen once you press the key (the defaulted screen is No.1). Generally, set the original system screen to be main menu or most used screen.
	Turn the screen to the last page

	Turn the screen to the next page
	Inquiry, jump to the user appointed screen
	To write the modified value in the register and continue modifying next register. After the last register in the screen has been modified, it will quit the setting.
	Alarming list key. After setting the function of alarming list, press this key to jump to the alarming list screen.
	Clear the selected area when modifying the register data.
	Set the positive or negative of the data when modifying the register data.
	Number key 0-9, press the key to set the number you want
	Function key F1-F6

NOTE:

Besides the function listed in the up table, all the keys can be defined as the function of “force ON”, “force OFF”, “reverse” or “momentary ON”.

Please see below picture. Open TouchWin software, put a button or function button in the screen. Choose “enter” in the window, all the key-presses can be found in this menu. User can set the key function as they need.

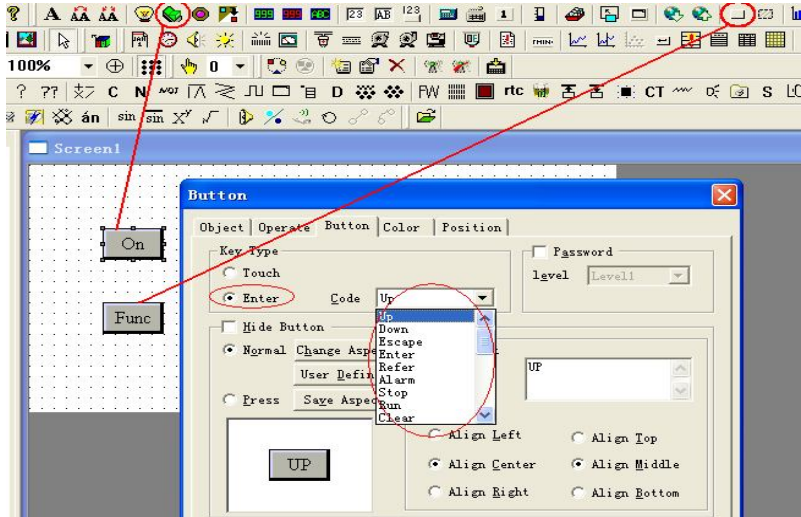

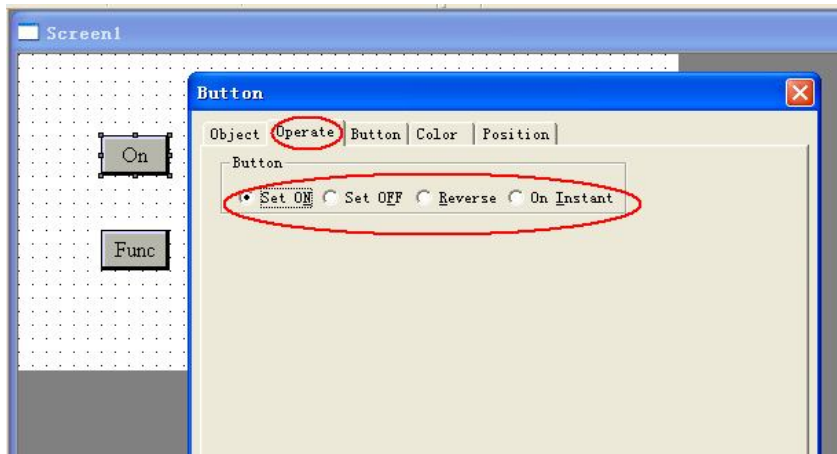

4-2 Build a project

Please use Touchwin software.

Open the software, click “File---New” or click  to build a new project.

Choose “MP760-T(XMP-32)” in the panel window:

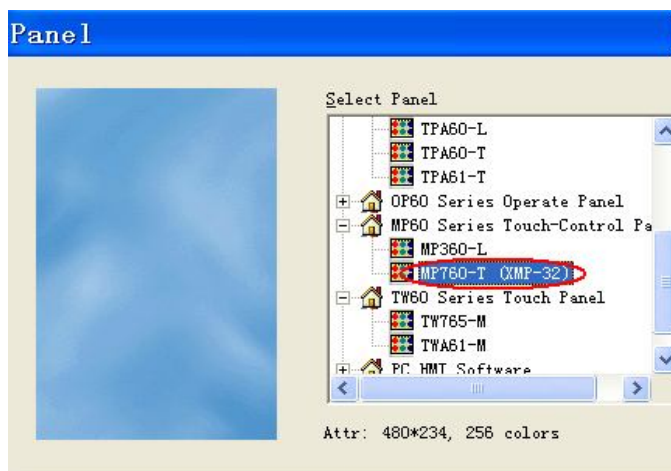

Click “next”, choose “Xinje XC series” for PLC port device:

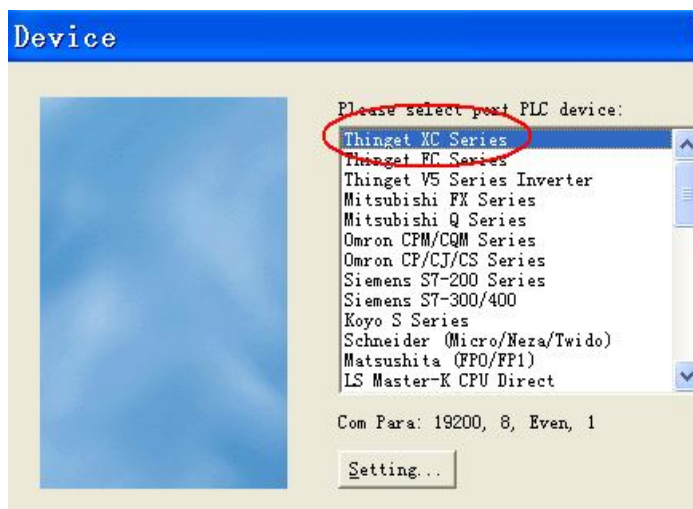

Click “next”, choose “Unuse download port” for download port device:

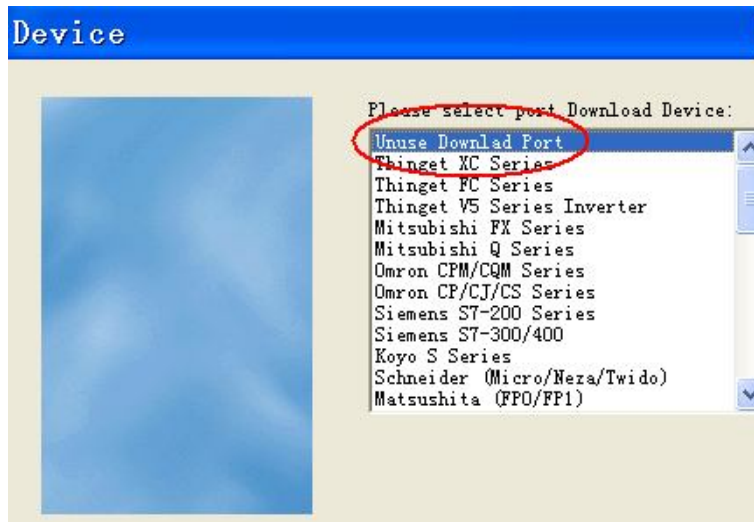

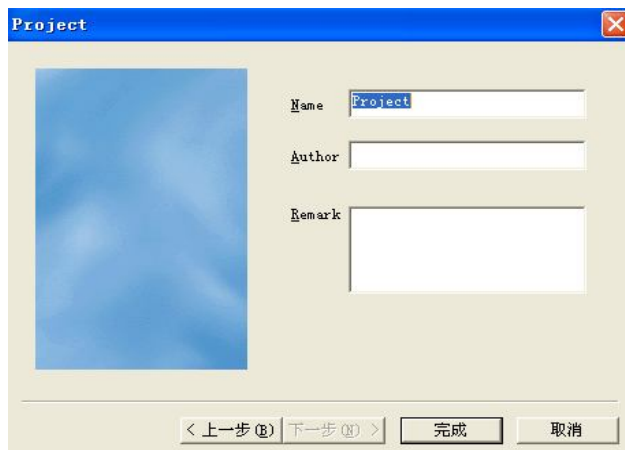

Click “next” to complete the building.

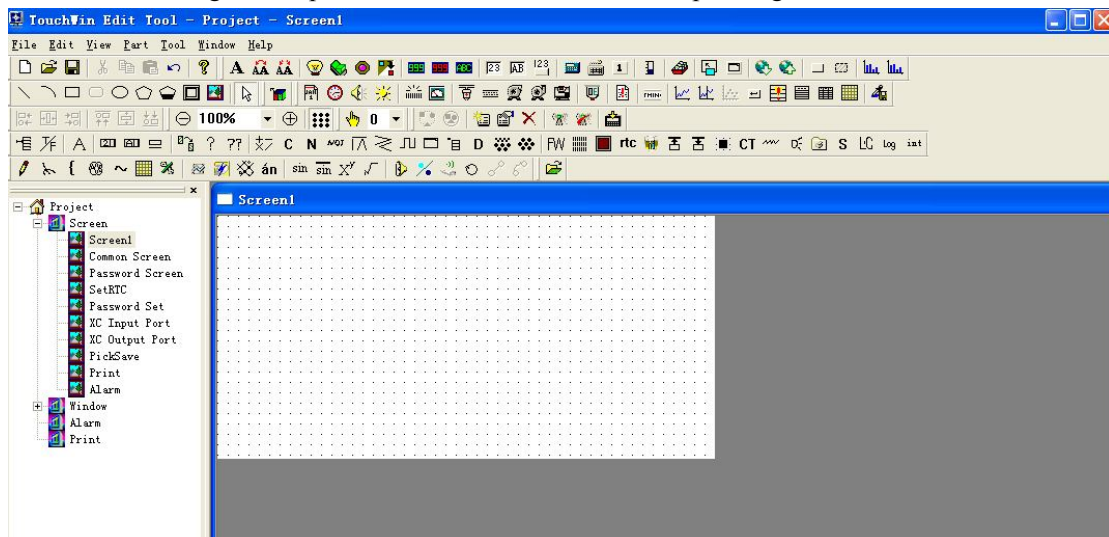

The editing interface is as below:

The software using details please refer to TP Touch Screen Operating Manual.



After completing the project editing and saving, connect the download port of XMP and computer serial port with downloading cable, make sure the XMP power is on. Click  or “File---Download” to start downloading data, the download window is as below:

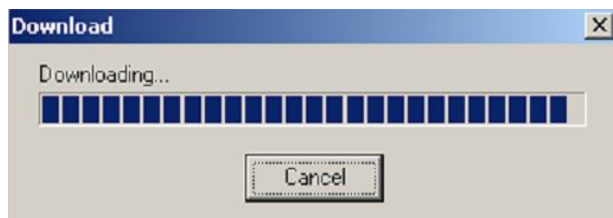

If it appears the item “connection overtime, check cable”, please download again. The downloading is completed when popping up below window:



Attention:

- (1) Do not cut the power when downloading, or you have to download again.
- (2) The downloading cable of downloading TouchWin screen is the same as downloading PLC program.
- (3) Do not download when XCPPro and TouchWin software are both opened.

5. The extension ability

5-1 Summarization

XMP2-32 series product can not extend BD board.

For extending other devices, use RS-232 or RS-485 (point A and B) com port.

RS-232 com port can connect with computer, HMI to monitor the program.

RS-485 com port can connect with meter, inverter, function model, etc. It can extend 32 exterior devices at most.

Attention:

The connection method is Bus mode, transmission line should start from station 1 to station 2, then from station 2 to station 3....., connect as this sequence until the last station. Star mode or ring mode connections are not permitted.

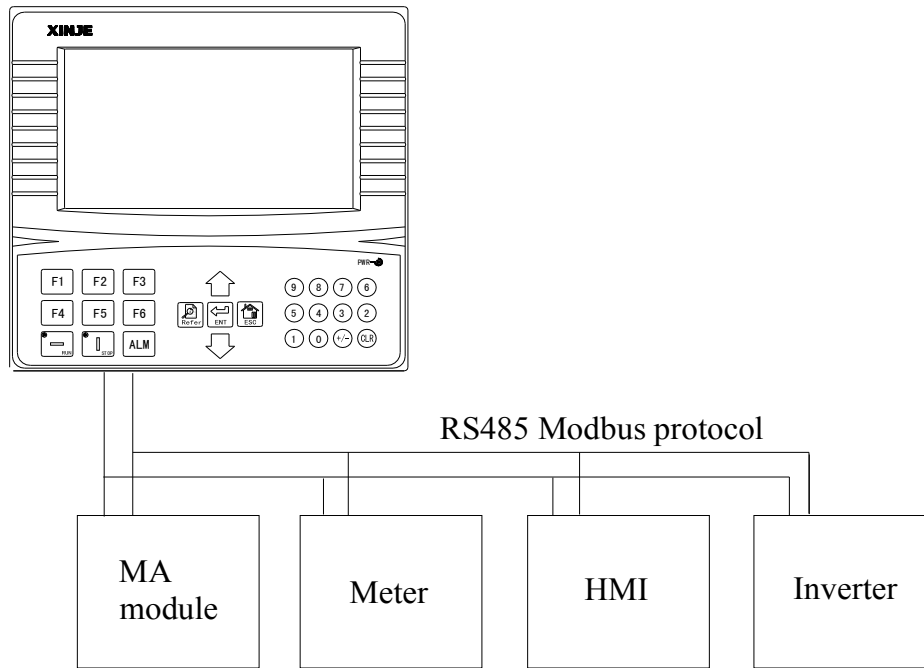

5-2. Extend MA model

XMP2-32 series product can extend MA model via RS-485 com port (A and B point) in order to control and measure analog quantity.

The type and specs of MA model are as below:

MA model type

Type	Function
MA-8X8YR	8 channels digital input, 8 channels digital output
MA-16X	16 channels digital input
MA-16YR/T	16 channels digital output
MA-4DA	4 channels analog output
MA-4AD	4 channels analog input
MA-8AD-A/V	8 channels analog input
MA-4AD2DA	4 channels analog input, 2 channels analog output
MA-6TC-P	6 channels type K thermocouple temperature control
MA-6PT-P	6 channels PT100 temperature control

MA model specs

Type	Description
MA-8X8YR	8 channels digital input, 8 channels digital relay output
MA-16X	16 channels digital input
MA-16YR	16 channels digital relay output
MA-16YT	16 channels digital transistor output

MA-4DA

Item	Voltage output	Current output
Analog output range	DC0~5V、0~10V	DC0~20mA、4~20mA
	(exterior load resistor 2K Ω ~1M Ω)	(exterior load resistor less than 500 Ω)
Digital input range	10 bits binary numbers	
Resolution ratio	1/1023 (10Bit)	
Integrated precision	0.8%	
Conversion speed	3ms/1 channel	
Power of analog quantity	DC24V \pm 10%, 100mA	
Installation	Use M3 screw or fix on DIN46277 rail (width 35mm)	
Profile dimension	63mm \times 102mm \times 73.3mm	

MA-8AD-A/V

Item	Voltage	Current
Analog input range	DC0~5V、0~10V	DC0~20mA、4~20mA
	(exterior load resistor 2K Ω ~1M Ω)	(exterior load resistor less than 500 Ω)
Maximum input range	\pm 18V	0~40mA
Digital output range	12 bits binary numbers	
Resolution	1/4095 (12Bit)	
Integrated precision	0.8%	
Conversion speed	20ms per channel	
Power supply for analog	DC24V \pm 10%, 100mA	
Installation	Use M3 screw or fix on DIN46277 rail (width 35mm)	
Profile dimension	63mm \times 102mm \times 73.3mm	

MA-4AD

Item	Analog input (4AD)	
Analog input type	Voltage input	Current input

Analog input range	0~5V,0~10V	0~20mA,4~20mA
Maximum input range	DC±18V	0~40mA
Digital output range	12 bits binary value (0~4095)	
Resolution	1/4095(12Bit)	
PID output range	0~K4095	
Integrated precision	0.8%	
Converting speed	20ms per channel	
Power for analog	DC24V±10%, 100mA	
Installation	Fix up the module with M3 screw or put on DIN46277 rail (width 35mm)	
Profile dimension	63mm×102mm×73.3mm	

MA-4AD2DA

Item	Analog input (4AD)		Analog output (2DA)	
	Voltage input	Current input	Voltage output	Current output
Analog input range	0~5V,0~10V	0~20mA,4~20mA	-	
Max input range	DC±18V	0~40mA	-	
Analog output range	-		0~5V、0~10V, (exterior load resistor 2KΩ~1MΩ)	0~20mA、4~20mA (exterior load resistor less than 500Ω)
Digital input range	-		10 bits binary number (0~1023)	
Digital output range	12 bits binary number (0~4095)		-	
Resolution	1/4095(12Bit)		1/1023(10Bit)	
PID output value	0~K4095			
Integrated precision	0.8%			
Conversion speed	20ms/1 channel		3ms/1 channel	
Power supply for analog quantity	DC24V±10%, 100mA			
Installation	Use M3 screw or fix on the DIN46277 (width 35mm) rail			
Profile dimension	63mm×102mm×73.3mm			

MA-6TC-P

Item	Specs
Using environment	0℃~60℃
Measure temperature range	0℃~1000℃
Digital output range	0~4095, 12 bits with sign, binary
Precision	1℃

Integrated precision	1℃
Conversion speed	20ms/1 channel
Power supply for analog	DC24V ± 10%, 50mA
Installation	Use M3 screw or fix on DIN46277 (width 35mm) rail
Profile dimension	63mm×102mm×73.3mm

MA-6PT-P

Item	Description
Analog input signal	Pt100 Pt hot resistance
Measure temperature range	-100℃～350℃
Digital output range	Full-scale 4095, 12 bits with sign, binary
Control precision	±0.1℃
Resolution	0.1℃
Integrated precision	0.8% (related maximum)
Conversion speed	20ms/1 channel
Power supply for analog	DC24V ± 10%, 50mA
Installation	Use M3 screw or fix on DIN46277 rail (width 35mm)
Profile dimension	63mm×102mm×73.3mm

MA model connection

XMP2-32 product can connect with MA model via RS-485 com port (A and B point). It can extend 16 MA models via setting DIP switch of MA model.

Please see the connection figure:

The details and using method please refer to MA Model Manual.

